

1KOMMA5°

1KOMMA5°

Full Black Bifacial Module

INSTALLATION MANUAL

Photovoltaic module models

- 1KOMMA5°-FullBlack-DG-01-445
- 1KOMMA5°-FullBlack-DG-01-450
- 1KOMMA5°-FullBlack-DG-01-455

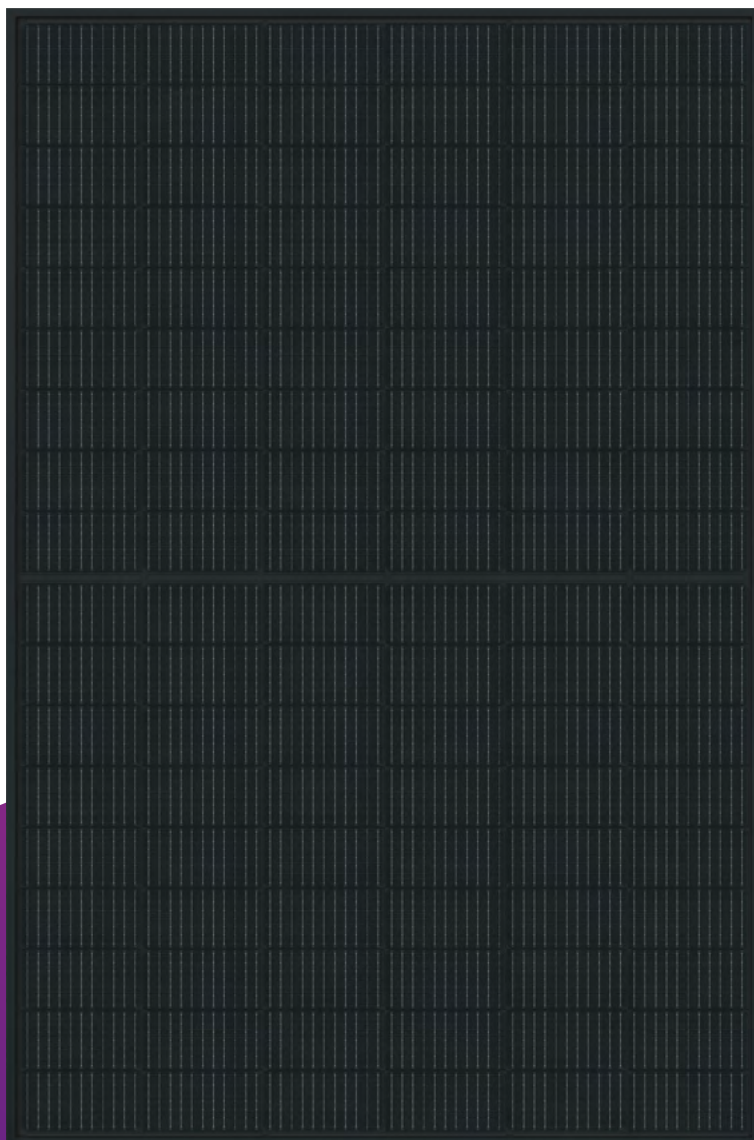

Change History

Version	Date	Change
1.0	02.04.2024	· Release of Preliminary Version
2.0	24.01.2025	· Release of Final Version

Installation Manual

Meets the safety requirements of IEC 61215 and IEC 61730

Electrical System

This installation manual contains important information regarding safety and the installation and operation of the modules that you should familiarise yourself with before using the modules.

Introduction	4
Safety Instructions	5
2.1 General Instructions	5
2.2 Safety precautions while working on the module	5
2.3 Safety precautions during installation	6
2.4 Safety precautions during storage and transport	8
Planning	9
3.1 Area of application	9
3.2 Electrical design	9
Series connection	10
Parallel connection	10
Combined connection	11
Mechanical installation	12
4.1 Installation site	12
4.2 Module alignment	13
4.3 Substructure	14
4.4 Clamping	15
4.5 Bolting	17
4.6 Installation methods	18
Electrical installation	20
5.1 Safety	20
5.2 Electrical connection	20
4.3 Earthing	22
Maintenance and care	24
6.1 Maintenance	24
6.2 Care	24
Disassembly and disposal	25
Liability Disclaimer	25

Introduction

This installation manual (“manual”) from 1KOMMA5° Technology GmbH, Neuer Wall 35, 20354 Hamburg, Germany (“1K5°”), outlines how to properly install the photovoltaic modules sold by 1K5° (“PV modules”). The manual only includes the PV modules offered under the 1KOMMA5° Full Black Module brand and installed in the spatial scope of applicability starting from 01.06.2023. The scope of applicability of this manual includes Australia, Denmark, Germany, Finland, Italy, Norway, Netherland, Spain and Sweden.

This document contains detailed instructions and safety precautions for the installation, electrical connection and maintenance. The PV modules may only be installed by certified installation technicians licensed by 1K5°. The notices and instructions in this manual must be followed. Non-compliance with the notices can result in personal injury and property damage. It is important to comply with all relevant safety regulations when planning and installing the PV modules. The installation manual must be kept near the PV modules for their entire service life. The installation manual must be passed on to the subsequent owner or user of the PV modules. Further applicable documents must be complied with. You can find more information on our website: 1KOMMA5.com.

The PV modules from 1K5° meet the requirements of IEC61215 and IEC61730 and are qualified for Application Class A (corresponds to the requirements of Safety Class II). The PV modules can be used in publicly accessible systems that work with more than 50 V DC or 240 W. The design of the module meets the requirements of IEC61730 and UL61730 and the fire rating class A (according to UL790).

Safety Instructions

2.1 General Instructions

In order to ensure that persons and PV modules are not harmed, it is important to comply with the following safety instructions. The entire PV module must be installed in accordance with recognised technical standards. All public regulations and specifications, national standards, technical connection conditions, accident prevention regulations, applicable guidelines set forth by the property insurer, technical rules set forth by the roofing trade and all other relevant guidelines must be complied with when planning, installing, operating and maintaining PV modules connected to the grid. The requirements may vary depending on the installation site, e.g., roof systems and open space systems. The requirements may also vary depending on the system voltage and DC/AC applications.

PV modules generate DC current when they are exposed to sunlight or other light sources. Irrespective of whether or not the PV module is connected, direct contact with the live parts of the module, e.g., the wiring connection, can result in injuries or even death. The safety of the installation technician and other persons involved must be ensured during the installation and use of the PV modules.

2.2 Safety precautions while working on the module

- Before installation, make sure the installation permit and requirements for the installation inspection meet the local requirements. During the installation, applicable safety regulations for all components must be complied with including cables, terminals, charging monitors, batteries, inverters, etc.
- The installation and maintenance may only be carried out by certified installation technicians licensed by 1K5°. Safety helmets, insulated gloves and safety shoes must be worn and insulated tools must be used during the installation in order to prevent direct contact with direct current of 30 volts or more. Working in a dry environment with dry tools is required.
- The modules should never be left unsecured and without a mount and we advise not stacking them to avoid damage.
- It is important not to walk on the module (front and back), not to let them fall and to protect them against falling objects. Leaning or kneeling on the modules (front and back) is prohibited.

- The PV modules should not be touched at the connection cables or connection socket and should not be carried in this manner, either. To remove and transport the module, using a glass suction cup or holding them only by the module frame is recommended. For longer transport routes, the modules should always be kept upright.
- It is important to avoid damaging or scratching the back of the module and the module must not be set down hard. Particular care is warranted when the module is set down on an edge.
- It is important to protect plug contacts against contamination and, if needed, to carry out appropriate cleaning measures.
- Do not drill or nail into the frames or weld anything to them. Do not drill any holes into the glass surface and do not apply paint or adhesive to the module.
- Modules with broken glass surfaces or cracks in the foil on the back are irreparably damaged and may not be used. Be careful, as any contact with the surface of the module or mount can cause electric shock. Broken or damaged modules should be disposed of in accordance with regulations.
- Do not disassemble, modify or alter the PV modules. Do not remove any parts that were installed by 1K5° unless you have first obtained approval. Otherwise, this may void the warranty.

2.3 Safety precautions during installation

- Do not install or handle modules in unsafe conditions including but not limited to strong winds or gust, sandy roofs.
- Do not allow children or unauthorized persons near the installation site or module storage area.
- When installing or operating PV modules on rainy days or dewy mornings, take appropriate protective measures to prevent moisture from penetrating the connectors.
- Before installation, the connection socket, cables and plug connectors must be checked for damage and contamination. No damaged or contaminated PV modules may be installed.
- If the PV modules are not installed on a level surface, suitable safety precautions must be taken and protective equipment must be used to prevent injuries and damage resulting from modules falling or other safety risks.
- Disconnecting conductors carrying DC current can result in flashover, therefore, before starting any work on the PV modules, in particular before disconnecting the plug connectors in the DC circuit, the inverter must be disconnected from the alternating current grid.

- When working on modules that are exposed to light, all provisions and directives pertaining to work on live electrical systems must be complied with. It must also be noted that the lowvoltage range (<120 V DC) can be exceeded when modules are connected in series, therefore, particular care is warranted.
- During the installation and operation while exposed to light, touching the electrical connection terminals or cable ends should be avoided. The PV modules, in particular, the plug connections and tools must be dry during the installation.
- When carrying out mechanical or electrical installation work, no jewellery or accessories made of metal may be worn. No electrically conducting parts may be inserted into the bushings or connection sockets.
- Electrical connections should never be interrupted and plugs should not be pulled out while the circuit is live.
- Touching electrically charged module components like connection terminals can result in burns, spark development and electric shock resulting in death, even if the module is not connected.
- Only insulated tools and rubber gloves approved for electrical installation work should be used.
- It is important to not put the module cables under mechanical stress and to ensure that drainage openings are not covered and that no water can flow in the direction of the plug connections.
- If needed, appropriate lightning protection measures must be taken. If the building has a lightning protection system, the module frames and the mounting system must be integrated into the exterior lightning protection system and additional surge protection devices may be necessary. Engaging a lightning protection specialist is recommended.
- Installation technicians are required to obtain information about fire safety guidelines and requirements for houses and buildings from the local authorities. The construction and installation on the roof can impact fire safety and errors in these areas can be dangerous in the event of a fire. If the modules are installed on the roof, they should be mounted on a fireproof surface approved for this purpose.
- If necessary, components like fault current switches and circuit breakers, fuses and charging switches should be installed.
- The PV modules should not be placed near devices or locations where gas is generated or can accumulate. PV modules should not be installed near easily inflammable materials or vapours. It is important to note that PV modules are not explosionprotected equipment.

2.3 Safety precautions during storage and transport

- The PV modules should be stored in a dark, dry and ventilated location. If the PV modules are stored in an environment that cannot be controlled, the storage period must not exceed 3 months if the exterior packaging remains intact.
- If the PV module is not in use, it should be stored in the original packaging from 1K5° and the packaging should be protected against being damaged.
- While transporting the PV modules to the project site, the PV modules must remain in the original packaging.
- Unloading the modules at wind speeds higher than 6 or in severe rain or snow is prohibited.
- Ensuring safety when unloading the PV modules is required. The PV modules should be placed in a protective device and then lifted onto the roof to prevent the packaging box from warping and hitting the wall during the lifting process.
- Before unpacking, make sure the packaging box is in good condition. The packaging tape and packaging foil should be carefully removed using appropriate tools. Forced removal is prohibited to avoid damaging the modules.

Planning

3.1 Area of application

The modules are only suitable for the following areas of application:

Recommended operating ambient temperature	-20°C to 50°C
Maximum operating ambient temperature	-40°C to +85°C
Maximum tested hail value	45 mm diameter 30.7 m/s velocity
Maximum tested load under standard installation conditions	+5,400 / -2,400 Pa
Rated load (taking a safety factor of 1.5 into account)	+3,600 / -1,600 Pa

3.2 Electrical design

- The nominal electrical values of the module are measured under standard test conditions (STC) (STC: 1,000 W/m² radiation strength, AM 1.5 spectrum and a cell temperature of 25°C).
- Only modules with the same output class may be connected to each other.
- The electrical properties and maximum system voltage and tolerances for I_{sc}, V_{oc} and P_{mpp} can be found on the PV module's data sheet or type plate.
- Since a module can deliver a higher current and/or higher voltage due to special environmental conditions, a safety factor of 1.25 must be taken into account for the electrical variables (V_{oc}, I_{sc}) under standard test conditions.
- Using UV-resistant PV cables is recommended. They must have a gauge of at least 4 mm² (12 AWG).
- The individual system components (modules, fuses, inverters, etc.) must be calibrated to each other according to their technical properties. Identical connection plugs (same manufacturer, same plug models) must be selected for the extension and connection cables.
- The local, regional and national regulations for the installation of electrical systems must be complied with.

Series connection

- The PV modules can be connected in series to achieve the desired total voltage. The current strength (I_{mpp}) of the modules connected in series should be the same because the maximum current is defined by the module with the lowest current strength.
- The maximum system voltage must be complied with and can be found in the "Technical Data – Maximum System Voltage" table or on the relevant module data sheet.
- The maximum number of modules in series results from the maximum system voltage (U_{sys}) divided by 1.25 times the opencircuit voltage (V_{oc}). The resulting number is then rounded down.

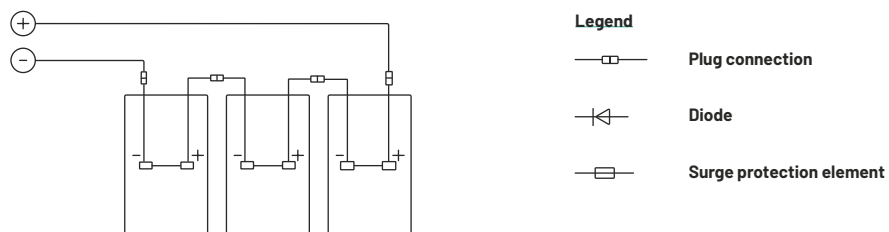

Parallel connection

- The modules can be connected in parallel to achieve the desired total current. The voltage (V_{mpp}) of the modules connected in parallel should be the same.
- To prevent back current, a back current fuse (e.g., blocking diode) is required.
- The cable gauge of the extension cable must be adapted to the maximum current carrying capacity of the circuitry.
- Only 2 strings may be connected in parallel.

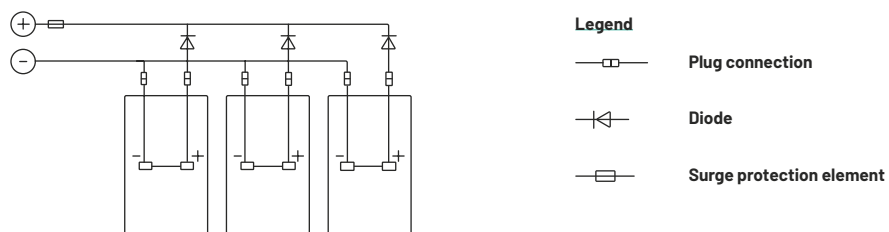

Combined connection

- The modules can also be connected in combination.
- All components must be calibrated to each other and the individual connection instructions, series and parallel connection must be taken into account.
- The same number of modules must be connected in the respective series string (same string voltage).
- Additional safety precautions must be taken to protect the cable and modules against surges.

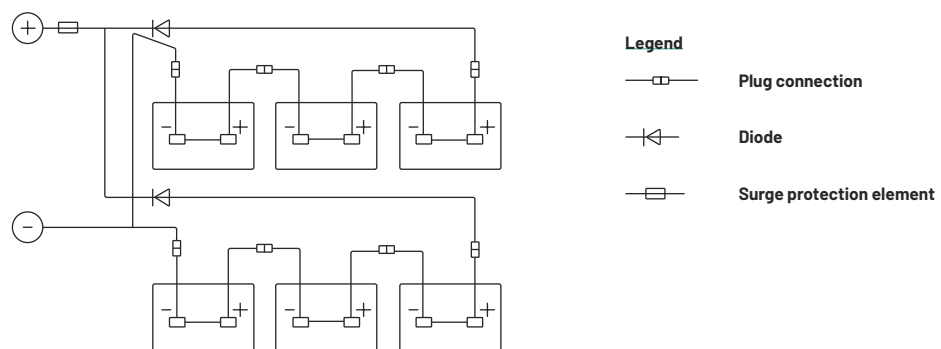

Mechanical installation

4.1 Installation site

The modules are only suitable for the following areas of application:

Permissible operating environment temperature	-20°C to 50°C
Permissible module operating temperature	-40°C to +85°C
Maximum tested load under standard installation conditions	+5,400 / -2,400 Pa
Rated load (taking a safety factor of 1.5 into account)	+3,600 / -1,600 Pa

The modules may not be installed in the locations specified below:

- in closed rooms
- above 2,000 m above sea level
- on the surface of a body of water
- in locations where backwater can accumulate (e.g., as a result of floods)
- near easily inflammable gases or vapours (e.g., petrol stations)
- in locations in which chemical substances might come into contact with parts of the module (e.g., oil or solvents)
- in the immediate vicinity of air conditioning and ventilation systems

Compliance with the following is also required:

- The modules must not be installed as a replacement for roofs or façades.
- For installations closer than 500 m from the sea, special precautions pertaining to earthing, maintenance and cleaning must be taken.

4.2 Module alignment

- To ensure fire resistance on the roof, the minimum distance between the frame of the PV module and the surface of the roof is 10 cm. For sheet metal and trapezoidal roofs, the minimum distance between the frame of the PV module and the nearest point of the roof can be reduced up to 4.5 cm.
- The modules can be installed upright or horizontally.
- Make sure no water can accumulate. Rain and runoff water must be able to drain freely. The drainage openings in the module frame must not be covered or sealed.
- The recommended minimum slope is 10°. The maximum slope must be determined in accordance with locally applicable regulations.
- Optimum sun exposure results in maximum energy yield. The PV modules should therefore be installed facing the sun. Shadows and partial shadows must be avoided (e.g., by trees, buildings, overhead lines, etc.).
- In the Southern Hemisphere, the modules should typically face north to achieve maximum energy yield.

The most important dimensions for the installation can be found in the following figure:

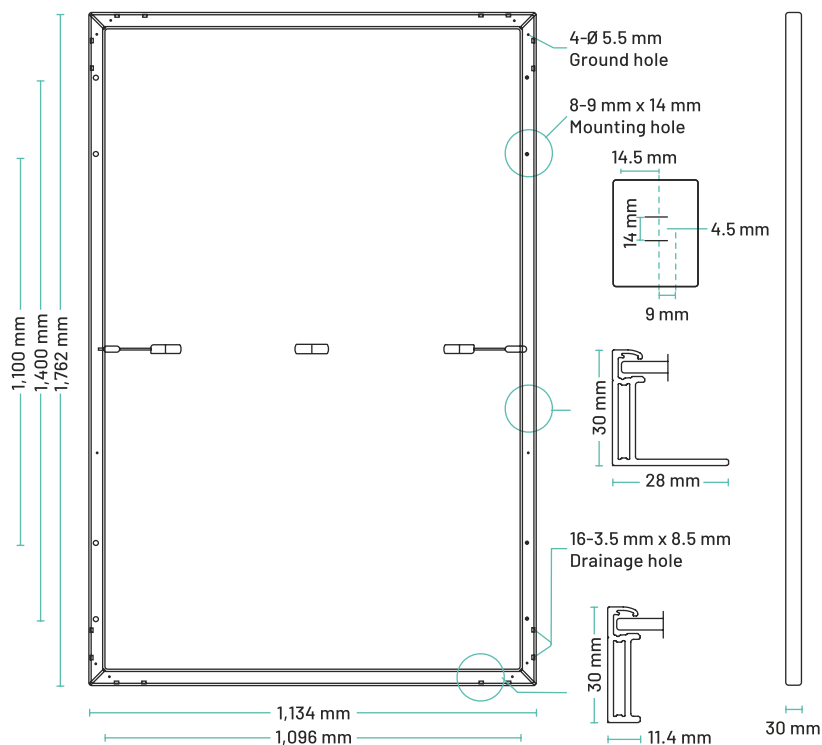

4.3 Substructure

- The substructure must be calculated and dimensioned based on the snow and wind loads. Uneven snow loads that can result in increased local loads must be avoided. In addition to the wind and snow loads, no further forces may impact the module.
- The substructure must be properly secured, either on the roof or floor. The forces that impact the module must be transferred to the substructure.
- No objects may be placed on the back of the module that might cause pressure concentration points when the modules deflect.
- Adequate cooling of the modules must be ensured.
- The mount must be designed without tension to allow length changes caused by temperature variations. Additional stresses and torques at the mounting points are not permitted.
- It must be ensured that the clamps or slidein profiles do not touch the glass, even when subject to loads.
- Below the connection socket, there must be a minimum distance of 50 mm to the substructure and other hard components. The cables must not get caught between the laminate and mounting rail when under high pressure. Laying the cable along the module frame is recommended.
- Contact between various metal materials must be avoided to avoid contact corrosion. Corrosion-resistant bolts and washers with the same material properties should be used to assemble the modules

4.4 Clamping

Clamps that meet the following requirements must be used:

Recommended clamp width	40 mm
Clamp depth	7 ~ 11 mm
Clamp height	for a module height of 30 mm

Compliance with the following is also required:

- All modules must be securely mounted with at least 4 clamps. The 9 x 14 mm mounting holes align with the M8 clamps.
- It must be ensured that the clamps do not touch the front glass of the module.
- The clamps must not cast any shadows on the cells when installed.
- The clamps must not damage or warp the module frame.
- The clamps must meet the structural analysis requirements at the respective sites.
- The clamps must be securely mounted on the mounting system.
- Using clamps with longterm stability that securely hold the modules on the substructure is recommended.
- The clamps must be installed according to the manufacturer's instructions, including the specific hardware and torque requirements. A maximum torque of 20 Nm must not be exceeded.

Each aluminium clamp is equipped with an M8 bolt, a washer, a spring washer and an M8 nut.

The installation steps are as follows:

01. Place the module on the two mounting rails, which are made of rustproof material and should be treated with a corrosion protection process (e.g. hot dip galvanising).
02. Each PV module requires at least four clamps to be mounted. The module clamps must not touch the glass or warp the frame as they might damage the module.
03. Avoid allowing the module clamps to cast shadows. Drainage openings on the module frame must not be covered or sealed by the clamps. The clamp must overlap with the frame at least 8 mm, but not more than 11 mm (the clamp diameter can be modified to ensure secure installation).
04. The top of the rail that touches the module frame should be equipped with grooves suitable for an M8 bolt.
05. If the grooves are not present, holes with a suitable diameter may have to be drilled to be able to mount the bolts on the rail at the above-mentioned positions.
06. Make sure the clamps are mounted in the following order: washer, spring washer and nut.
07. There are two types of clamps: the centre clamp and the edge clamp. The recommended dimensions of the clamp are: $a \geq 40$ mm, $b \geq 16$ mm, $c \geq 5$ mm, $d \geq 15$ mm, $\varnothing = 9$ mm. For modules with a wafer size of 182/210 mm, the size of the centre and edge clamps must be $a \geq 60$ mm. The tightening torque for bolts and Class 8.8 clamps is 17~23 Nm.

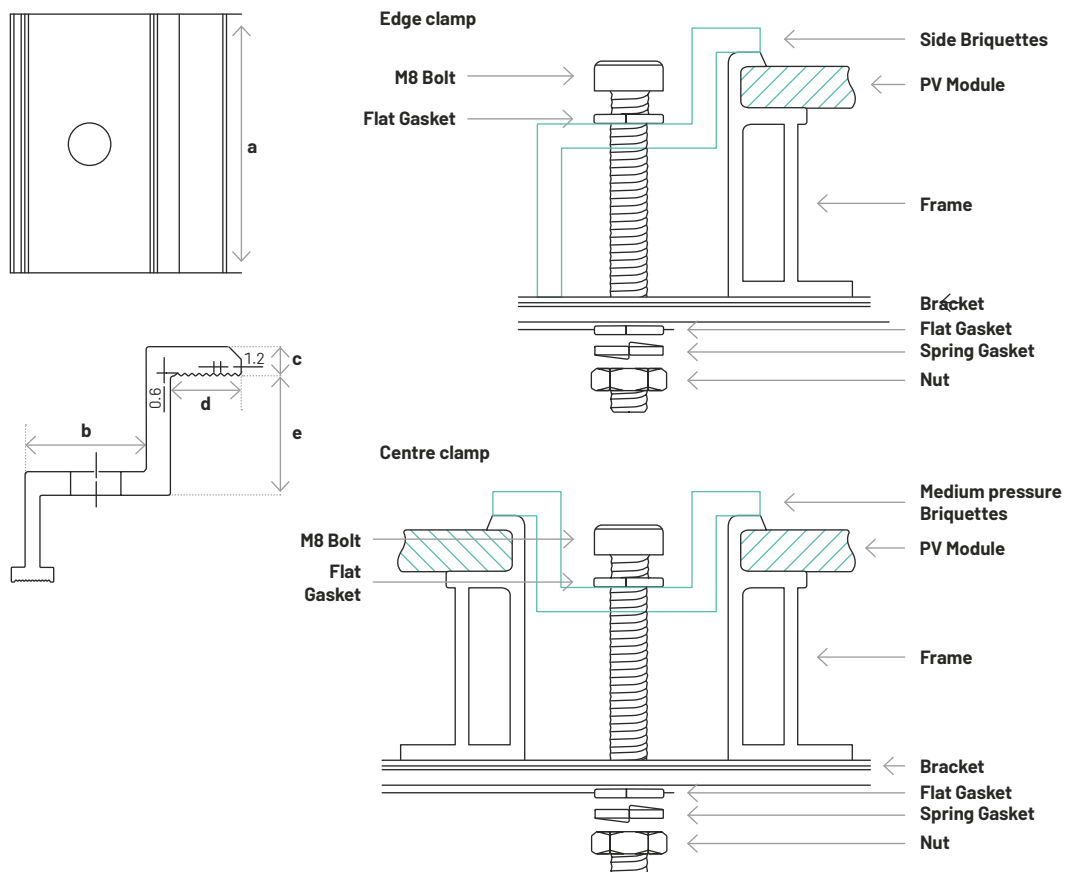

- 08. To prevent the PV modules from coming off the permanent mount after installation, using edge and centre clamps and having the A side of the frame in contact with groove patterns is recommended. 9 grooves with a spacing of 1.2 mm between two adjacent grooves and a depth of 0.6 mm are recommended.
- 09. When using installation method 2 (p. 18), the module must be mounted with professional clamps and the overlap between the C side of the module and the rail should be ≥ 15 mm.

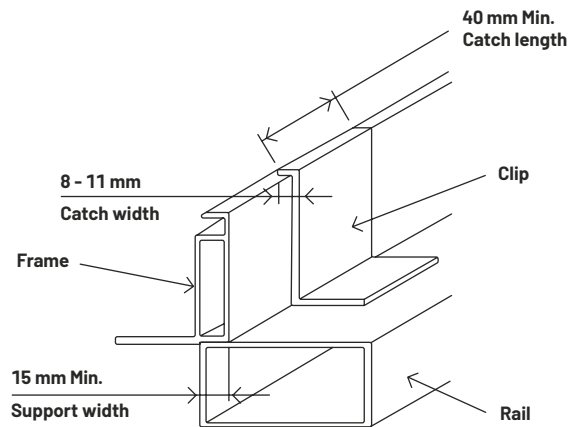

Mounting requirements for rails that overlap with the frame on the shortside

4.5 Bolting

In order to achieve maximum safety precautions against wind and snow loads, it is recommended that all available mounting holes should be used. The bolt installation steps are as following figure:

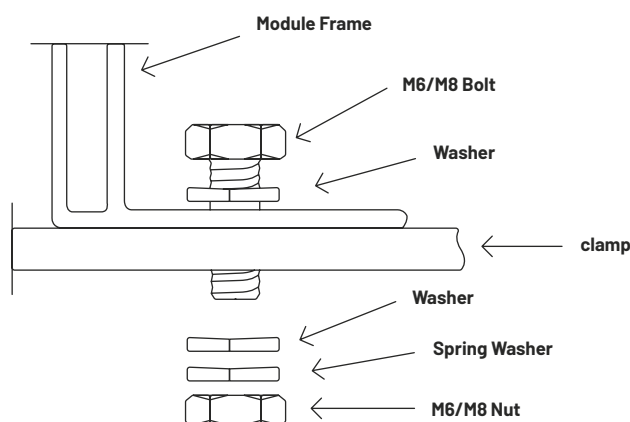

- Place the PV module on top of the rack. Insert 4 stainless steel bolts in corresponding mounting holes. The 9x14 mm mounting holes + 10mm mounting holes match with M6 bolts. 7x10mm mounting holes are positioned with a hole pitch of 400mm.
- Make sure to use two stainless steel washers for each bolt, one on each side of the rack, the minimum thickness of the washer is 1.5mm, and the outer diameter is 16~18mm, but for 210 wafer size modules, the outer diameter is 18~20mm, then screw on the top of a stainless-steel spring washer or toothed lock washer. Finally, lock with a stainless-steel nut. The tolerance requirements for flat gaskets are in accordance with the A-level standard in GB/T 3103.3-2020
- The tightening torque is recommended to be 9~12Nm for M6 bolts and 17~23Nm for M8 bolts. Due to the possible difference of bolt material, the specific torque value is subject to the information confirmed by the bolt supplier.
- When using 30 mm height frame module, it is recommended to select fasteners ≤ 20 mm length

4.6 Installation methods

The PV modules can be installed transverse to the mounting frame (installation method 1 and 3) or parallel to the PV module frame (installation method 2). The PV modules can also be mounted with four pivot points (installation method 4). "D" indicates the mounting range. When using clamps to mount the modules, each module must be mounted with at least 4 clamps. The clamping range can be extended up to 30 cm if the load is reduced accordingly and reliable installation is ensured.

Module model	1K5°-FullBlack-DG-01
Dimensions [L x W x H]	1,762 x 1,134 x 30 mm
Maximum mechanical test load [Pa]	+5,400 / -2,400 Pa
Design load Pressure/tension [Pa]	+3,600/-1,600 Pa

Installation method 1 Rails perpendicular to the long side of the frame

Test load [Pa] +5,400/-2,400 Pa

Mounting range [mm] 266 ~ 466 mm

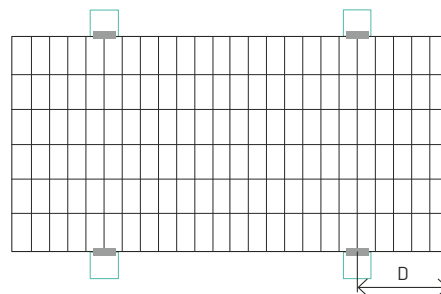

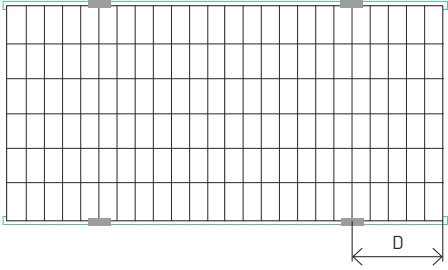
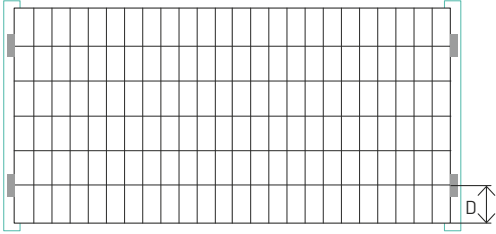
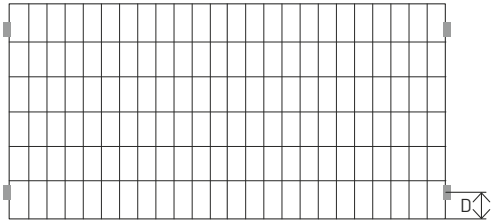
Installation method 2	Rails overlapping the long side frame	
Test load [Pa]	+3,600/-2,400 Pa	
Mounting range [mm]	2,660 ~ 466 mm	
Installation method 3	Rails that overlap with the frame on the short side	
Test load [Pa]	+1,800/-1,800 Pa	
Mounting range [mm]	150 ~ 250 mm	
Installation method 4	Four clamps on the short side of the frame	
Test load [Pa]	+1,200/-1,200 Pa	
Mounting range [mm]	0 ~ 250 mm	

Electrical installation

5.1 Safety

The previously mentioned safety precautions must be taken during installation (p. 5f).

5.2 Electrical connection

The nominal electrical values of the module are measured under standard test conditions (STC: 1,000 W/m² radiation strength, AM 1.5 spectrum and a cell temperature of 25°C). The most important electrical properties and maximum system voltage and tolerances for I_{sc}, V_{oc} and P_{mpp} can be found on the product's data sheet or type plate.

Under certain conditions, the output current and/or the output voltage of the PV module may be higher than the value specified under standard test conditions. Therefore, the value specified on the PV module for I_{sc} should be multiplied by 1.25 and V_{oc} should be multiplied by a correction factor when the nominal values and capacities of the components are determined. Depending on the local regulations, an additional multiplier of 1.25 can be applied to the I_{sc} value (total 1.56) when dimensioning conductors and fuses.

Lowest estimated ambient temperature (°C)	Correction factor	Lowest estimated ambient temperature (°C)	Correction factor
24 ~ 20	1.02	-11 ~ -15	1.16
19 ~ 15	1.04	-16 ~ -20	1.18
14 ~ 10	1.06	-21 ~ -25	1.20
9 ~ 5	1.08	-26 ~ -30	1.21
4 ~ 0	1.10	-31 ~ -35	1.23
-1 ~ -5	1.12	-36 ~ -40	1.25
-6 ~ -10	1.14		

Alternatively, a more precise correction factor can be calculated for Voc based on the following formula:

$$C_{VOC} = 1 - \alpha_{VOC} \times (25 - T_{MIN})$$

In this formula, C_{VOC} is the correction factor for V_{OC} . α_{VOC} (%/°C) is the temperature coefficient of the PV module's open-circuit voltage (see data sheet) and T_{MIN} (°C) is the expected lowest ambient temperature at the system installation location.

The string voltage must not be higher than the maximum system voltage and the maximum input voltage of the inverter and other electrical devices installed in the system. To ensure the above-mentioned requirements are met, the open-circuit voltage of the string must be calculated using the following formula:

$$\text{Maximum system voltage} \geq N * V_{OC} * C_{VOC}$$

In this formula, N is the number of PV modules in a single string and V_{OC} is the open-circuit voltage of the individual PV modules (see data sheet).

Depending on the maximum fuse values of the PV modules and the local standards for the electrical installation, the parallel connection of PV modules must be equipped with suitable fuses or protective diodes to protect the electrical circuit. All electrical calculations and planning work must be carried out by a certified installation technician licensed by 1K5°.

When connecting modules or loads like inverters and batteries, make sure to check the polarity of the cables to ensure the normal operation of the system. If the PV module is not connected correctly, the bypass diode may be damaged. PV modules can be connected in series to increase the voltage. When connecting in series, the wire from the positive terminal of a module is connected to the negative terminal of the next module. PV modules can be connected in parallel to increase the current by connecting the positive connection of a module to the positive connection of the next module. If module is not connected correctly, the bypass diode may be damaged.

The number of PV modules connected in series or in parallel should be designed in a practical manner based on the system configuration. PV modules with different electrical output models cannot be connected in a string. Suitable cables and plugs for PV systems must be used for the installation. It must be ensured that all connections are securely mounted. The cables must be 4 mm² (i.e., 12 AWG) and be able to withstand the maximum possible open-circuit voltage of the PV system.

When mounting the cable to the frame, mechanical damage to the cable or PV module must be avoided. To properly mount the cable to the frame, specially developed UV-resistant coils and cable terminals must be used. The cables must be protected against sun exposure and water.

Plugs must be kept dry and clean. It should be ensured that the nuts on the plugs are properly tightened before they are connected. Plugging in or pulling the plugs when the PV module is live is prohibited. If the plug connector has to be disconnected, it must be ensured that the PV module is not in operation and that professional unlocking tools are used and safety measures are followed.

The connection socket on the PV module is equipped with bypass diodes that are connected in parallel to the PV module's string. The bypass diode in the connection socket prevents the module from degrading due to shadows or being covered. When a local hotspot phenomenon occurs in the PV module due to the module being partially shaded or covered, the diode in the connection socket will start working so the module current no longer flows through the hotspot cell in order to limit the heat and loss of the PV module. If a diode fault is suspected or determined, opening, pulling on or tugging on the cover on the connection socket is prohibited.

5.3 Earthing

The PV modules are equipped with a frame made of anodised, corrosion-resistant aluminium alloy and is a rigid mount. To ensure safety and prevent lightning strikes and electrostatic damage to the PV modules, the frame of the PV modules must be properly grounded in accordance with local and national electrical codes.

The earthing requirements must be checked in accordance with the applicable regulations and standards before starting work. If earthing is required, it is recommended to use the marked 5.5 mm earthing bores to earth the anodised frame. Moreover, one M5 nut, two M5 washers, one M5 washer, one M5 spring washer and one M5 bolt and a copper wire should be used. All nuts, clamps and washers should be M5 made of stainless steel.

If earthing is required, follow these steps:

01. Put the bolt through the washer and wrap the copper wire around the screw. Please note that the copper wire must not be directly mounted on the aluminium.
02. Put the bolt through the washer and then through the hole in the aluminium frame.
03. Add and tighten the spring washer and the nut on the other side of the bolt to secure all of the parts. The tightening torque should be 4 ~ 4.5 Nm.

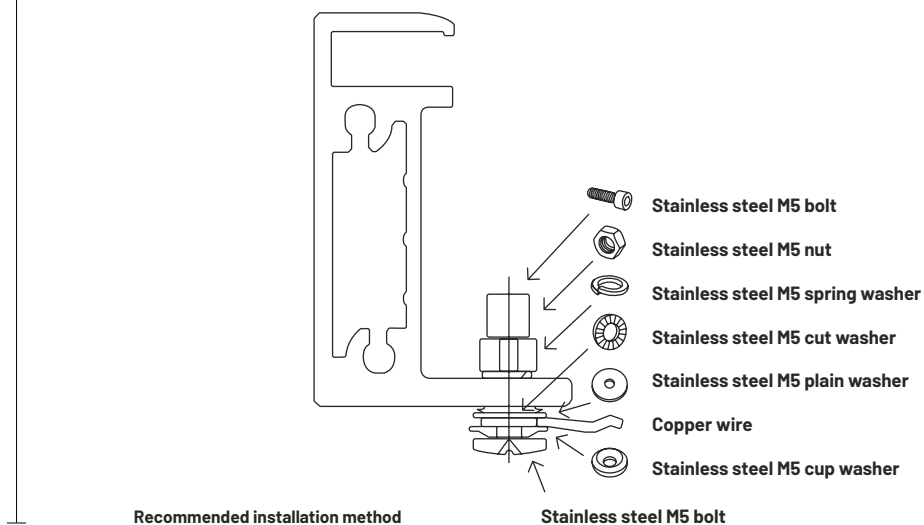

If earthing is required, the following instructions must be complied with:

- UL-467-certified connection and earthing units, including Burndy (formerly Wiley Electronics) Washer Electrical Equipment Bonding (WEEB) and similar units must be used, e.g. washers with barbs that meet the requirements of UL-467 and are suitable for the electrical connection and earthing of PV modules.
- Other earthing methods can be used if the rack system is tested in accordance with the requirements of UL 2703.
- Drilling additional earthing holes in the module frames is prohibited. The frame rails have predrilled holes that are marked with an earthing symbol. These holes should be used for earthing, not mounting the modules.
- The module must be earthed in accordance with national, regional and local regulations.

Maintenance and care

6.1 Maintenance

- The system should be regularly inspected by a certified installation technician.
- The glass surface, the frame and the connections should be regularly checked for damage.
- All electrical components should be inspected to ensure they are free of corrosion and the connection contacts are good.
- If a module has to be replaced, follow the disassembly and disposal instructions (chapter 7). In addition, a module with the same electrical properties should be used.
- After an extraordinary weather event (storm, hail, snow, etc.), the modules should be checked for damage by a certified installation technician.

6.2 Care

- Do not clean the modules until they have cooled down.
- The glass should never be touched with bare hands as this can leave fingerprints. Instead, rubber gloves should be worn when carrying out maintenance, washing or cleaning the modules in order to protect the PV modules from being damaged and the installation technician from electric shocks.
- Carefully remove leaves, snow, ice or other contamination using a broom. If there is sand or heavier dirt, be careful in order to avoid scratches.
- A generous amount of water should be used to remove heavy contamination. Do not use tap water; instead, only use demineralised water or rainwater. Stubborn contamination can also be soaked.
- The use of the following agents and items is prohibited: abrasive cleaning agents like abrasive powders, polishing compound, steel wool and scrapers, cleaning units made of steel, chemical cleaning agents; acids, lye, bleach powder and strong alkalines; high-pressure cleaners, steam blasters or brushes.
- Cleaning agents that are highly acidic or alkaline, cleaning agents containing hydrofluoric acid (HF) and pure alcohol or pure acetone may not be used.
- The ingredients of cleaning products should be checked before use. Manual cleaning or hand washing can be carried out using alcohol-based cleaning agents. Cleaning can also be carried out using a soap-water solution. Cleaning agent residues should be removed from the surface of the glass.

7

Disassembly and disposal

Compliance with the following instructions is required while disassembling the modules:

- The system may only be disassembled by certified installation technicians licensed by 1K5°.
- Before disassembly, the inverter must be switched off and its switch-off interval must be completed. The modules must be disconnected from the inverter.
- The components should be inspected for damage.
- The plugs must be disconnected using suitable specialist tools.
- The PV modules and the substructure must be disassembled using suitable specialist tools.
- PV modules and other components should be securely packed for transport.

Our partner, take-e-away, picks up and disposes of PV modules. You can find more information on their website: <https://kundenportal.take-e-way.de/>

8

Liability Disclaimer

1KOMMA5° Technology GmbH has no influence on the use of this installation manual and the conditions and procedure applied during the installation, operation, use and maintenance of the PV module. Therefore, 1K5° Technology GmbH assumes no liability for losses, damage, injuries or costs incurred as a result of or in conjunction with the installation, operation, use and maintenance of the module and expressly rejects liability in such cases. 1KOMMA5° Technology GmbH does not assume any liability for patent violations or violations of other third-party property rights the use of the module might cause. The use does not include any implied or other granting of licenses in accordance with any patents or patent laws.

The information in this manual is based on the expertise and experience of 1KOMMA5° Technology GmbH and has been found to be reliable. Information, product specifications and recommendations are neither of an explicit nor an implicit guarantee nature. 1KOMMA5° Technology GmbH reserves the right to make changes to the product, the specifications or this manual without prior notice.

1KOMMA5°

CONTACT

1KOMMA5° Technology GmbH
Neuer Wall 35
20354 Hamburg
Germany
service@1KOMMA5GRAD.com